

Dance Notation Bureau (DNB)

<http://www.dancenotation.org/Inbasics/frame0.html>

Folk Dance: Cherkessia, Israeli Dance

From the southeastern part of Russia the Cherkessians introduced this dance to Palestine. It is a broken circle dance, which was originally performed entirely by men. The dancers stand side by side with arms down and hands joined. Children also enjoy this dance because it can become a game of follow the leader. The leader introduces different steps in (B) section. Each section is performed a total of four times.

Remember, Labanotation is read from the bottom up.

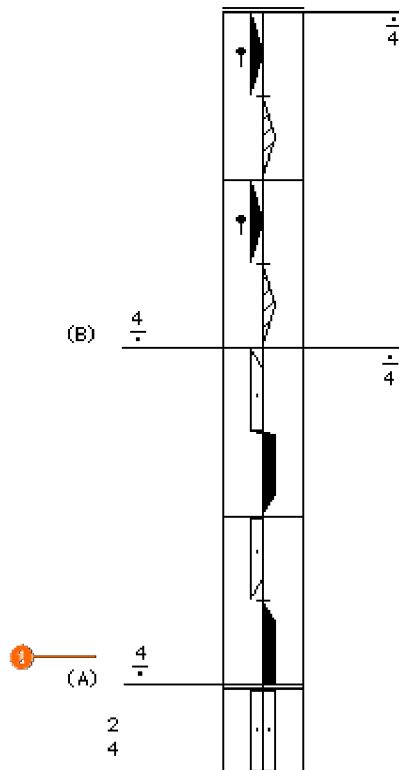

$\frac{4}{4}$ = performs a total of four times.

Section A is danced four times and then section B is done four times.